

DESIGN GUIDELINES FOR IMPROVED AVAS APPLICATION USING SOUND RADIATION ANALYSIS

Prof. Dr. Alessandro Fortino^{1*}

Jan Kotzian, M.Eng.¹

¹ Department of Mechanical Engineering, University of Applied Science and Arts Dortmund, Germany
Sonnenstr. 96-100, 44139 Dortmund

ABSTRACT

In recent years, the number of new registrations of electric vehicles has increased significantly in Europe and reached a value of over 870.000 BEV in 2021 [1]. Starting from July 1st, 2021, all newly registered electric vehicles need to be equipped with an Acoustic Vehicle Alerting System (AVAS) according to UN Regulation No. 138 in order to improve the audibility in the lower speed range. Although some parameters regarding total SPL and frequency composition are already defined in the regulation, there remain numerous tuning and design parameters for the respective sound designers. Typically, the sound design process starts with the creative artwork. Speaker design, speaker placement and the surrounding vehicle parts have a major impact on the resulting sound radiation and the initial concept needs to be adjusted according to the sound radiation characteristics in the complete vehicle setup. In this paper an approach is presented, in which the sound radiation of the AVAS is analyzed and improved first and the sound design process will be based on these results. With the help of this data, sound designers can align the AVAS setup more effectively with the desired development targets.

Keywords: AVAS, Sound Design, Speaker, Sound Radiation

1. INTRODUCTION

The past decade has witnessed remarkable transformations in the field of mobility. Hybrid Electric Vehicles (HEV) and Battery Electric Vehicles (BEV), once considered niche, are experiencing increasing demand year by year. In fact, they have already surpassed the registration figures of popular internal combustion engine (ICE) car models in certain European markets [2]. On one hand, electric drivetrains offer a huge advantage for reducing urban noise emissions in the lower speed range underneath 30 km/h. On the other hand, moving an electric car almost completely silent can result in dangerous situations between vehicles and visually impaired or distracted pedestrians. Unlike visual detection, the sense of hearing can detect objects in all directions and accurately locate approaching vehicles within a 3D environment. For this reason, car manufacturer are mandated to equip electric vehicles with AVAS, not only to assist the visually impaired but also to enhance overall safety by restoring the ability to perceive traffic situations audibly at an early stage. After establishing AVAS in the first place, the OEM (original equipment manufacturer) are facing a central question: How should an electric car sound and how should the sound design process be approached? It is important to recognize that the AVAS sound should not only convey the legally required acoustic information but also be pleasant and contribute to establishing or reestablishing a desired brand image. Initiating the system design of an AVAS solely based on simulation tools is often not the easiest or resilient solution due to the high number of acoustic elements involved, such as frequency dependent speakers and nearby reflective objects, which significantly impact the overall acoustic performance. Hence, this paper will discuss experimental methods that prioritize analyzing sound radiation as a means to identify modifiable AVAS setups that align with specific sound design requirements for targeted development goals.

*Corresponding author: alessandro.fortino@sh-dortmund.de

Copyright: ©2023 Alessandro Fortino et al. This is an open-access article distributed under the terms of the Creative Commons Attribution 3.0 Unported License, which permits unrestricted use, distribution, and reproduction in any medium, provided the original author and source are credited.

2. AVAS REQUIREMENTS

Car manufacturers must adhere to various noise emission regulations for electric vehicles to ensure compliance and facilitate the sale of their cars in specific markets. As mentioned earlier, European markets, as well as non-EU markets like Australia, South Korea, and South Africa, must comply with UN R138. With the introduction of this regulation, electric vehicles have to meet requirements regarding the minimum sound pressure level, the frequency content and the frequency characteristics in terms of a pitch shift of at least 0.8 % per km/h in the speed range from 5 to 20 km/h [3]. However, the US market deviates from the specifications outlined in UN R138 and follows different criteria under FMVSS 141. Key aspects of the US requirements that differ from UN R138 are the speed range in which a hearable sound is required and the frequency range for additional noise emissions. Not only does the US market require a mandatory sound during standstill when the car is ready to drive but also the maximum test speed is increased to 31 km/h [4]. Especially the frequency requirements have a significant impact on the sound quality of the AVAS. Thus, it becomes crucial to compare and analyze the contrasting regulations as an initial step (see Figure 1) to gain insights and understand the specific requirements of each regulation.

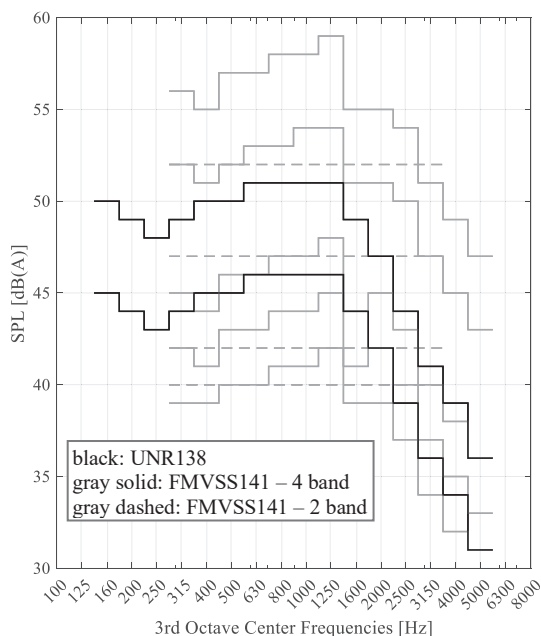

Figure 1. AVAS frequency requirements UN R138 and FMVSS 141

Under UN R138, two 3rd octave bands in the frequency range from 160 Hz to 5000 Hz and regarding FMVSS 141 two or four 3rd octave bands in the range from 315 Hz to 3150 Hz (2-band) / 315 Hz to 5000 Hz (4-band) have to fulfill the illustrated minimum sound pressure level values. It is evident from the overview that both regulations predominantly focus on the mid- and high-frequency areas, in which the human ear is very sensitive. At the same time, the requirements have a significant impact on the AVAS sound characteristics themselves. While not mandated by law, it is possible to incorporate sound components in the lower frequency range below 160 Hz. However, this often introduces conflicts in terms of the required speaker type and speaker enclosure volume, posing challenges in achieving the desired sound quality.

Recent statistics show that even electric vehicles equipped with AVAS continue to be involved more often in accidents with visually impaired pedestrians. Consequently, the German Association for the Blind and Visually Impaired has expressed concerns about the AVAS requirements, particularly regarding the lower perception threshold and overall characteristics [5], [6]. Based on this feedback, there is a desire for the AVAS to resemble more the characteristics of a vehicle equipped with an ICE, and there is a call to extend the sound requirements to higher vehicle speeds.

3. COMPONENT DESIGN

One of the initial and most important parameters that significantly affects the overall frequency characteristics of the AVAS is the selection and design of the speaker itself, including the speaker enclosure. Even at this early stage of system design, there is a need to strike a balance between various development goals, such as:

- Acoustic performance (e.g., frequency range)
- Package and installation space requirements
- Weight
- Total system costs

It is evident that choosing a larger speaker with a larger membrane diameter would improve performance in the lower frequency range. However, this would also result in increased weight and dimensions. To assess the impact of the speaker choice on the overall AVAS performance, speakers with different characteristics, such as size, sensitivity, and maximum power level, have been preselected for integration into a test vehicle. For a better comparison of the test results, all speakers possess a static impedance of approx. 4 Ohms. While the primary purpose of a speaker is dynamic excitation, conducting an impedance analysis initially can provide valuable insights:

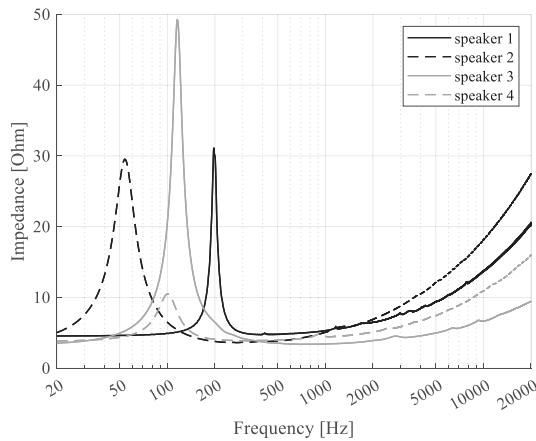

Figure 2. Impedance measurements of different speaker types

Four different speakers with varying frequency range have been used in this studies, which can be seen in the variation of the eigenfrequencies in the range from 50 Hz to 200 Hz. Above the eigenfrequencies, a consistent impedance of 4 Ohm can be noted up to a frequency of 1 kHz. For a better design of the AVAS, the speaker eigenfrequency should be in the range of the first mandatory 3rd octave bands starting at 160 Hz. All selected speakers fulfill this requirement, although a lower eigenfrequency is recommended to facilitate the creation of more immersive and powerful sound concepts. Notably, speaker 2 demonstrates the best performance in this regard. Another aspect of the sound design process is the decision on the 3rd octave bands that will be used to meet the requirements of UN R138 and FMVSS 141. Figure 3 showcases the sound radiation analysis of speaker 2 in conjunction with the speaker enclosure for selected 3rd octave bands.

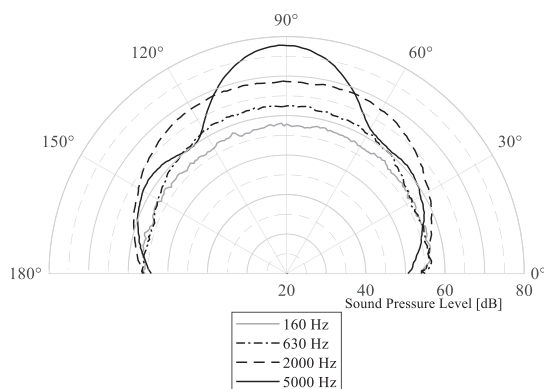

Figure 3. Sound radiation in selected 3rd octave bands of speaker 2

Going from lower frequencies to higher frequencies, the impact of the comb filter effect becomes more prominent. The 160 Hz 3rd octave band is radiated in all directions almost equally. However, the highest AVAS frequency of 5000 Hz, shows significant areas of destructive interference at approximately 60° and 120°.

The results do not only show the context of the frequency and the radiation characteristics but also emphasize the importance of the decision regarding the orientation of the speaker membrane after vehicle integration. Assuming that the membrane faces the direction of travel, the AVAS test microphones will be positioned on the left and right sides of the vehicle, 2 meters away, corresponding to 0° and 180° in the radiation analysis shown in Figure 3. Selecting 5 kHz for the AVAS application would require more energy to be directed into the control unit due to a reduced transfer of approximately 50 dB at 1 W power consumption to these microphone positions. When the microphone is facing directly towards the speaker at 90°, 77 dB can be measured. The increase of +22 dB compared to the side positions show a highly unbalanced behavior which can lead to unnecessary noise pollution in front of the vehicle if this frequency would be chosen during the sound design process of the AVAS.

4. VEHICLE INTEGRATION

Following the analysis of sound radiation characteristics at component level, various configurations for the AVAS installation were tested in a BEV. To accurately assess the acoustic performance, measurements were conducted in a semi-anechoic chamber, as depicted in Figure 4.



Figure 4. Setup with BEV in semi-anechoic chamber and rotatable microphone arm

To accommodate packaging constraints, speaker 1 and speaker 4 were integrated into the front of the vehicle in an eccentric position, with the speaker pointing towards the left side of the vehicle. In contrast, speaker 2 was centrally positioned with its membrane facing downwards. It is worth noting that AVAS systems are typically installed only in the front of the vehicle, despite the requirement in all markets for measuring noise emissions at the rear while reversing. This is why the radiation analysis has been carried out on both vehicle sides with the rotatable microphone arm. Figure 5 shows the exemplary results of the 2 kHz 3rd octave band results.

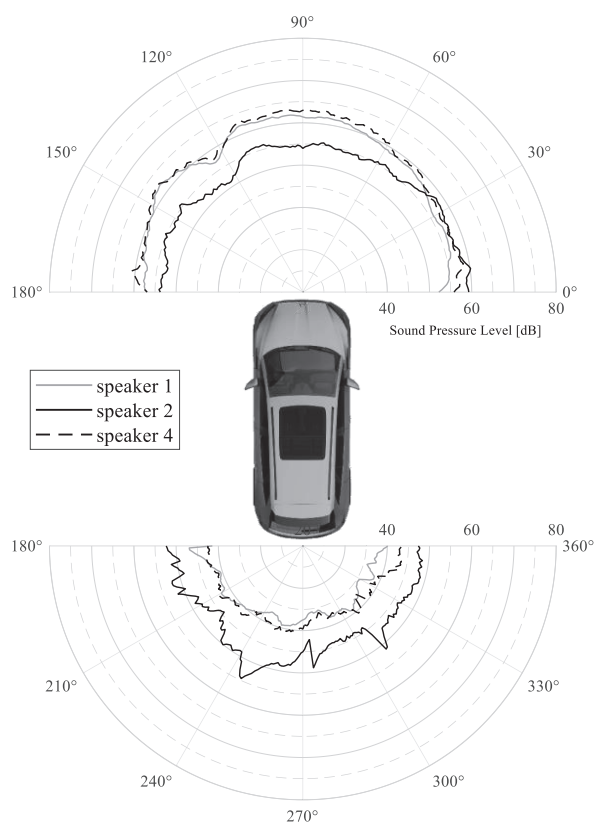

Figure 5. Sound radiation at 2000 Hz 3rd octave band in front and in the back of the vehicle with different speaker configurations

Especially in the higher frequency range of the 2000 Hz band the eccentric mounting positions of speaker 1 and 4 lead to increased SPL on the left side of the vehicle compared to the right side. Although the sound radiation of centric speaker 2 is underneath speaker 1 and 4 in a wide range in front of the vehicle, the setup of speaker 2 is the most promising one for a homogenous AVAS

setup. At the most relevant position for the AVAS validation (0°) best results with up to 10 dB difference to the eccentric setups can be obtained. Furthermore, when examining the sound transmitted to the back of the vehicle, the superiority of the centric AVAS layout becomes even more apparent.

5. SUMMARY

The research conducted has provided valuable insights into the influence of both speaker integration and component design on AVAS sound radiation. It has become evident that achieving the optimal system design for acoustic performance and homogeneous sound radiation may be challenging due to various constraints in series production vehicles. Therefore, it is highly recommended to conduct a sound radiation analysis before or in parallel with the actual sound design process. By selecting 3rd octave bands with a favorable power-to-sound ratio and symmetrical radiation, the noise pollution on secondary positions and the total energy consumption of the AVAS can be reduced leading to a more energy-efficient electric vehicle.

6. ACKNOWLEDGMENTS

We would like to thank the Federal Institute for Occupational Safety and Health for the opportunity to conduct full vehicle measurements in their semi-anechoic chamber.

7. REFERENCES

- [1] European Environment Agency: “New registrations of electric vehicles in Europe”, 2022.
- [2] C. Seyerlein: “Erstmals mehr Tesla Model 3 als VW Golf in Deutschland zugelassen“, Automobil Industrie, 2021
- [3] United Nations: „UN Regulation No. 138 - Uniform provisions concerning the approval of Quiet Road Transport Vehicles with regard to their reduced audibility“, 2017
- [4] U.S. Department of Transportation: “FMVSS 141 - Minimum Sound Requirements for Hybrid and Electric“, Washington DC, 2020.
- [5] Deutschlandfunk: “E-Autos sollen besser zu hören sein“, 2023
- [6] Unfallforschung der Versicherer: “Wahrnehmung von Beschleunigung (mit AVAS)“, Berlin, 2022